

ANALYSIS OF HYBRID SYSTEM USING FEED FORWARD NEURAL NETWORK

Chandrakant jaiswal¹, Dharmendra kumar singh²

¹M Tech scholar, Department of Electrical and Electronics Engineering, C V Raman University bilaspur, C.G., India

²Associate Professor, Department of Electrical and Electronics Engineering C V Raman University Bilaspur, C.G., India

Email - ckjaiswal13@gmail.com

ABSTRACT: Nowadays, renewable energy resources play an important role in replacing conventional fossil fuel energy resources. Photovoltaic energy is one of the very promising renewable energy resources which grew rapidly in the past few years. Photovoltaics has one major problem and which is that with the variation of the operating conditions of the array, the voltage at which maximum power can be obtained from it also changes. In the thesis, a PV model is used to simulate actual PV arrays behavior, and then a Maximum Power Point tracking method and wind energy system using Feed Forward Neural networks is proposed in order to control the power. Furthermore the proposed feed forward neural network technique using hybrid system is compared with the ANFIS (adaptive neuro fuzzy interference system). Simulation results shows that the proposed feed forward neural network maximum power point tracking method gives faster response than the ANFIS under rapid variations of operating conditions. In electric distribution system Power control of a hybrid generation system that is wind and solar system for interconnection operation is presented in this paper. Renewable resources such as the solar wind etc. offers clean, abundant energy. As the power demand increases power failure also increases so the renewable energy can be used to provide constant loads. To converting the basic circuit equation of solar cell into simplified form a model developed including the effects of changing solar irradiation and temperature. This paper consists of PMSG as a wind generator, solar array and grid interface inverter. Power control strategy is used to extract the maximum power. Maximum power point tracker (MPPT) control is essential to ensure the output of photovoltaic power generation system at the maximum power output as possible. There are many MPPT technique. In this paper incremental conductance (IncCond) method is used and simulated in Mat lab/Simulink. P&O method is simple in operation and hardware requirement is less, but it has some power loss. IncCond method has more precise control and faster response, but it has higher hardware requirement. In order to achieve maximum efficiency of photovoltaic power generation, an efficient control methods that is (P&O) should be chosen. The voltage source inverter interface with grid transfers the energy drawn from the wind turbine and PV array to the grid by keeping common dc voltage constant. The simulation results show the control performance and dynamic behavior of the hybrid wind-PV system.

Keywords : PV Array, Wind Energy System, Utility grid, 3-level bridge Inverter, Feed forward neural network

1. INTRODUCTION:

Renewable energy resources play an important role in electric power generation. There are various renewable resources which is used for electric power generation, such as solar energy, wind energy, geothermal etc. Solar Energy is a good choice for electric power generation, since the solar energy is directly converted into electrical energy by solar photovoltaic modules. These modules are made up of silicon cells. When many such cells are connected in series we get a solar PV module. The current rating of the modules increases when the area of the individual cells is increased, and vice versa. When many PV modules are connected in series and parallel combinations we get a solar PV array, which is suitable for obtaining higher power output. The applications of solar energy are increasing, and many

researches are done to improve the materials and methods used to harness this power source. Main factors that affect the efficiency of the collection process are solar cell efficiency, intensity of source radiation and storage techniques. The efficiency of a solar cell is limited by materials used in solar cell manufacturing. It is particularly difficult to make considerable improvements in the performance of the cell, and hence restricts the efficiency of the overall collection process. Therefore, the increase of the intensity of radiation received from the sun is the most attainable method of improving the performance of solar power. There are two major approaches for maximizing power extraction in solar systems. They are sun tracking, maximum power point (MPP) tracking or both. Later on in this thesis, two MPP tracking techniques are studied and compared. The technique is based on feed forward neural networks and the second one is based on the incremental conductance method. In electric distribution system Power control of a hybrid generation system that is wind and solar system for interconnection operation is presented in this paper. Renewable resources such as the solar wind etc offers clean, abundant energy .As the power demand increases power failure also increases so the renewable energy can be used to provide constant loads. To converting the basic circuit equation of solar cell into simplified form a model developed including the effects of changing solar irradiation and temperature. This paper consists of PMSG as a wind generator, solar array and grid interface inverter. Power control strategy is used to extract the maximum power. Maximum power point tracker (MPPT) control is essential to ensure the output of photovoltaic power generation system at the maximum power output as possible. There are many MPPT technique. In this paper incremental conductance (IncCond) method is used and simulated in Mat lab/Simulink. P&O method is simple in operation and hard ware requirement is less, but it has some power loss. IncCond method has more precise control and faster response, but it has higher hardware requirement. in order to achieve maximum efficiency of photovoltaic power generation, an efficient control methods that is (P&O) should be chosen. The voltage source inverter interface with grid transfers the energy drawn from the wind turbine and PV array to the grid by keeping common dc voltage constant. The simulation results show the control performance and dynamic behavior of the hybrid wind-PV system.

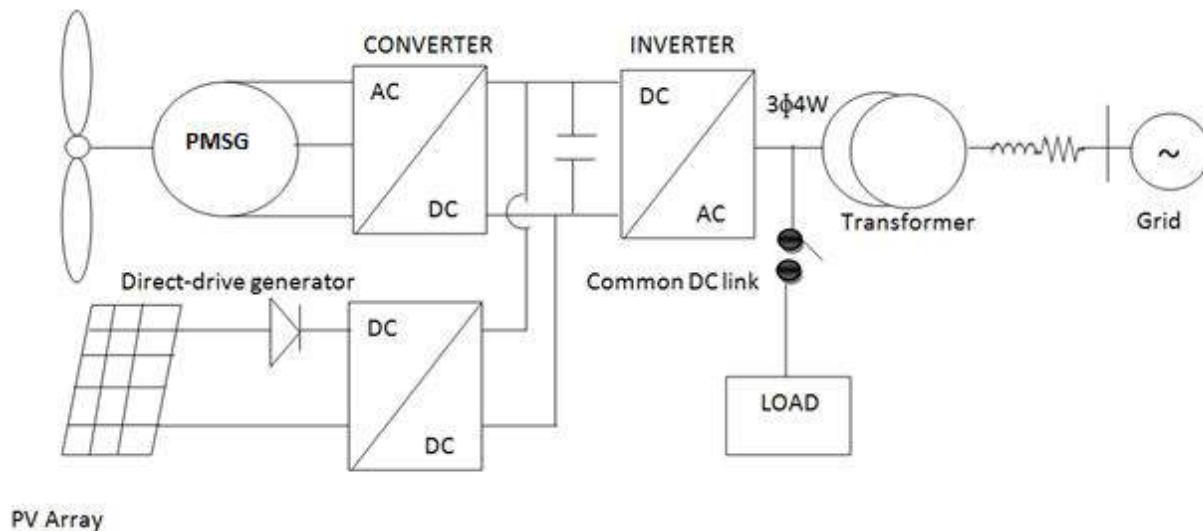

Fig. 1.1 system representing Grid-connected hybrid wind/PV

Objectives:

- The basic objective of this paper is to extract maximum power and to maintain power quality to a satisfactory level from the varying condition of the wind as well as from the Photovoltaic array with different solar irradiation.
- To capture the maximum power from the PV system, maximum power point tracking is applied& for wind turbine to capture maximum power variable speed control technique is used.

1.1 Modeling of a Solar Cell:

PV array are formed by combine no of solar cell in series and in parallel. A simple solar cell equivalent circuit model is shown in figure. To enhance the performance or rating no of cell are combine. Solar cell are connected in series to provide greater output voltage and combined in parallel to increase the current. Hence a particular PV array is the combination of several PV module connected in series and parallel. A module is the combination of no of solar cells connected in series and parallel.

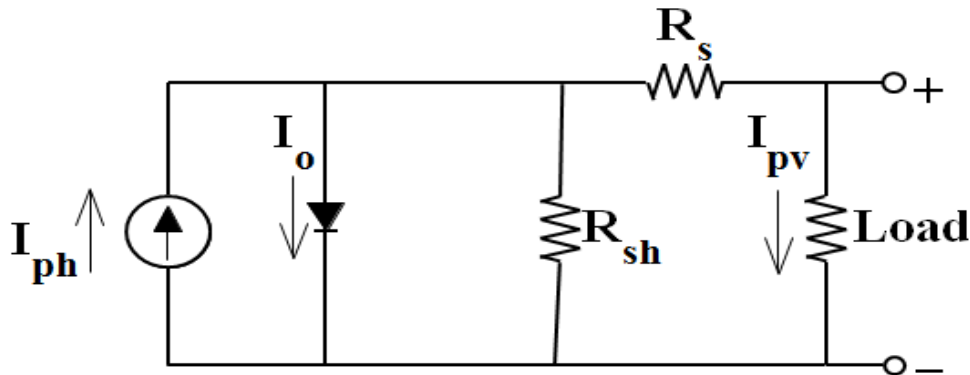

Fig.1.2 Circuit diagram of a single PV cell

The result shows the nonlinear characteristics of photovoltaic array at different irradianations and temperature

Table 1 : Solar Module (60 W) Specification	
Rating	60W
Current at Peak	3.5 A
Voltage at Peak	17.1 V
Short circuit current	3.8 A
Open circuit voltage	21.1 V
Total number of cells in parallel	36
Total number of cells in series	18

1.3 Wind Turbine:

Wind is a form of solar energy and it is available everywhere. Always wind blows from a higher atmospheric pressure region to the lower atmospheric pressure region due to the non uniform heat by the sun and due to the rotation of the earth. In other words we can say that wind is a form of solar energy available in the form of that kinetic energy of air.

Wind energy can change into many form of energy, such as wind turbine is used to generate electricity, mechanical power windmills for water lifting wind pumps, also in propelling ships. Wind energy is capable of supplying large amount of power and the total amount of obtainable power available from the wind is considerably more than the present human power used from all the sources. Wind power is an alternative of fossil fuels, is plentiful, widely expanded, clean, and renewable and during operation no

greenhouse gas produced. Wind power is the fast growing source of energy.

Day by day, the development of the wind energy improving and if it is use properly then it is capable to fulfill the growing demand of the consumer, also growing of the force acting on blades moving through air. There is also development of turbines with two or three blades. For successful electricity generation high speed and high efficiency of turbines were the necessary conditions.

By using the power of the wind wind turbines produce electricity by drive an electrical generator. Amoving force is exerted and generates lift when wind is passing over the blades. The rotating blades rotate the shaft which is connectedwith the gearbox. The gearbox adjusts the rotational speed which is convenient for the generator to get a desired output. The output of the wind generator is fed to the transformer which converts the electricity of the generator up to 33 kv.Which is the appropriate voltage for power system.

Rating	10 kW
Diameter	8 m
Number of blades	3
Cut in speed of wind	3 m/s
Cut out speed of wind	25 m/s
Rated Wind speed	12 m/s
Air density	1.225 kg/m ³

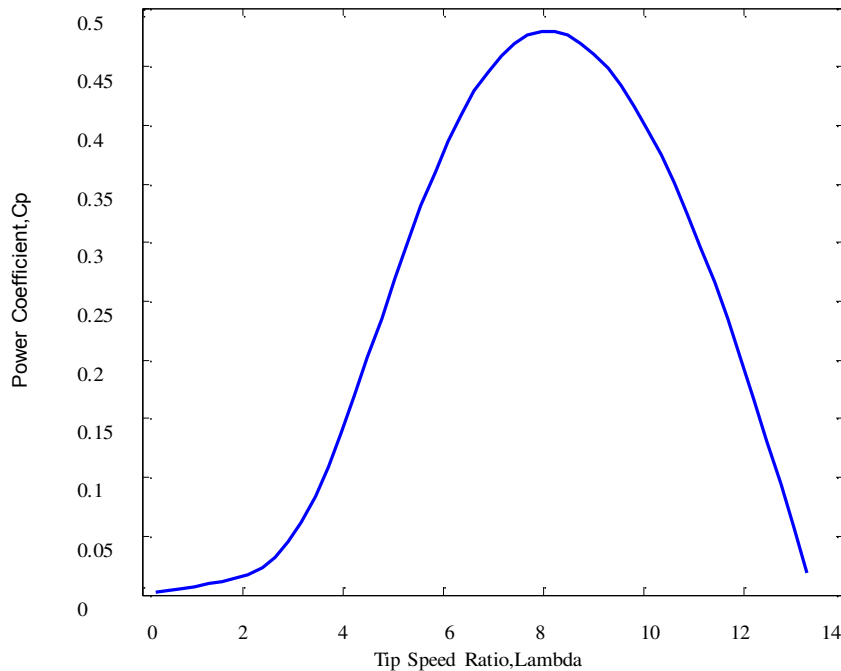

Fig.1.3 Characteristics of C_p vs λ curve

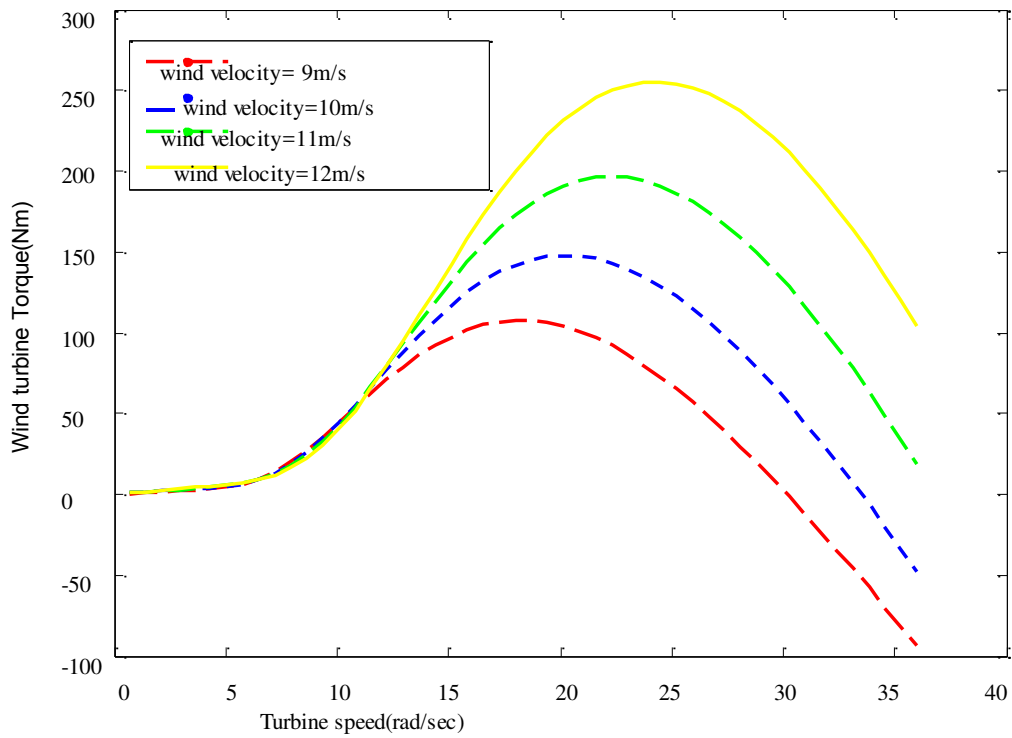

Fig.1.4 Characteristics of torque vs speed with different wind speed

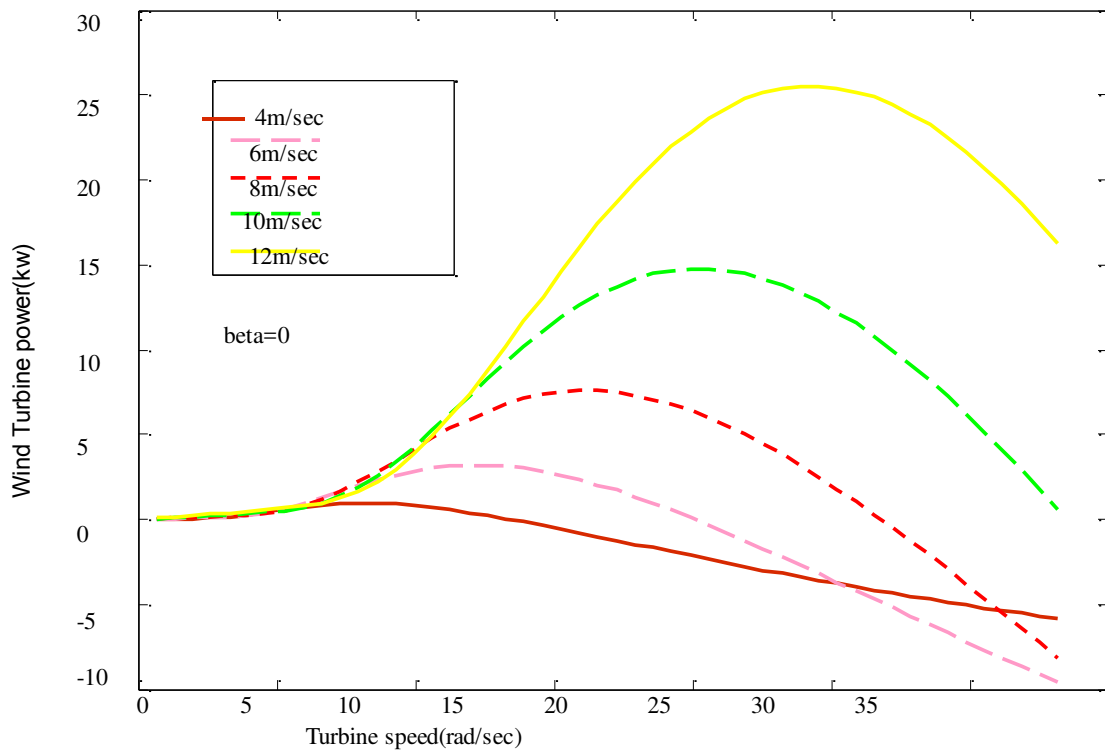

Fig.1.5 Characteristics of power vs speed with different wind speed

1.4 FAMOUS MPPT METHODS:

Conventional methods:

The most famous conventional MPPT methods are the Perturb and Observe (Hill climbing) method, the Incremental Conductance method, the Fractional open circuit voltage method and the Fractional short circuit Current method.

Artificial intelligence methods:

There are two main AI methods, Fuzzy logic based MPPT and Neural Networks based ones.

Both ANFIS and FFNN methods have their advantages and drawbacks. ANFIS methods are famous for their easy implementation and compatibility to operate with any Photovoltaic array, while their disadvantages is that they are considered relatively slower than the FFNN methods and not only that they show slow response in sudden temperature and solar irradiance changes, but also they may fail in tracking the maximum power point.

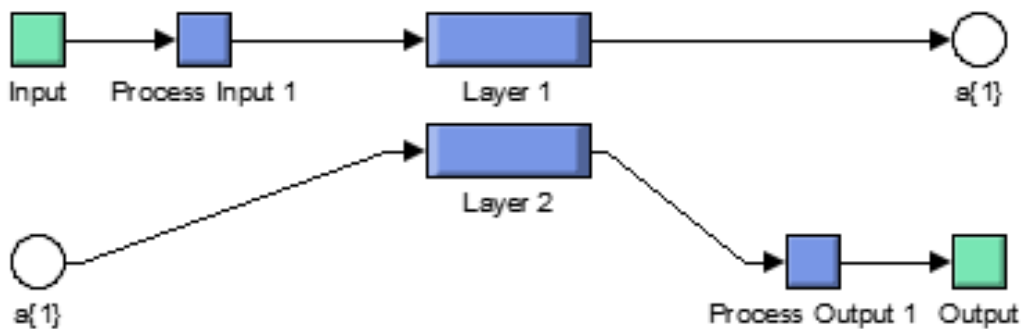

Fig 1.6 shows the model of feed forward neural network

On the other hand, artificial intelligence methods show very fast response under any operating condition changes, give very accurate results and they are able to work under instant temperature or solar irradiance changes efficiently. The drawbacks of the AI methods that they are complicated in design, they need very fast processors to be implemented physically or otherwise they will run very slowly. For each PV array type, a separate model should be designed to guarantee that it will perform well which is considered also a disadvantage.

1.5 INCREMENTAL CONDUCTANCE METHOD:

This algorithm, shown below, compares the incremental conductance to the instantaneous conductance in a PV system. Depending on the result, it increases or decreases the voltage until the maximum power point (MPP) is reached. Unlike with the P&O algorithm, the voltage remains constant once MPP is reached.

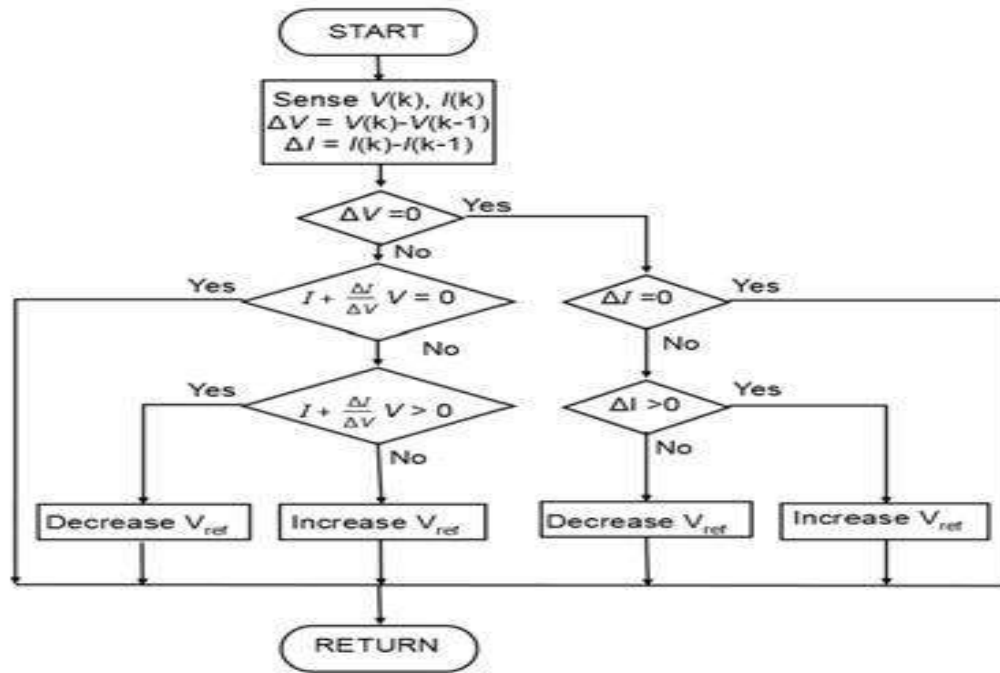

Fig. 1.7: Incremental Conductance algorithm flow chart.

With this algorithm the operating voltage V is perturbed with every MPPT cycle. As soon as the MPP is reached, V will oscillate around the ideal operating voltage. This causes a power loss which depends on the step width of a single perturbation i.e. the larger the step is, the larger the oscillations around voltage of maximum power is and vice versa. If the step width is large, the MPPT algorithm will be responding quickly to sudden changes in operating conditions with the tradeoff of increased losses under stable or slowly changing conditions. If the step width is very small the losses under stable or slowly changing conditions will be reduced, but the system will be only able to respond very slowly to rapid changes in temperature and solar irradiance. The value of ideal step width is system dependant and needs to be experimentally determined.

One drawback of the IC algorithm is in case of sudden increase in the solar irradiance, the P&O reacts as if the increase occurred as a result of the previous perturbation of the array operating voltage. The next operation, therefore, will be in the same direction as the previous one which may be the opposite direction of maximum power. Figure shows that the continuous perturbation in one direction will lead to an operating voltage away from the MPP voltage. When the irradiance change decreases or stops the MPPT will get back to its normal behavior.

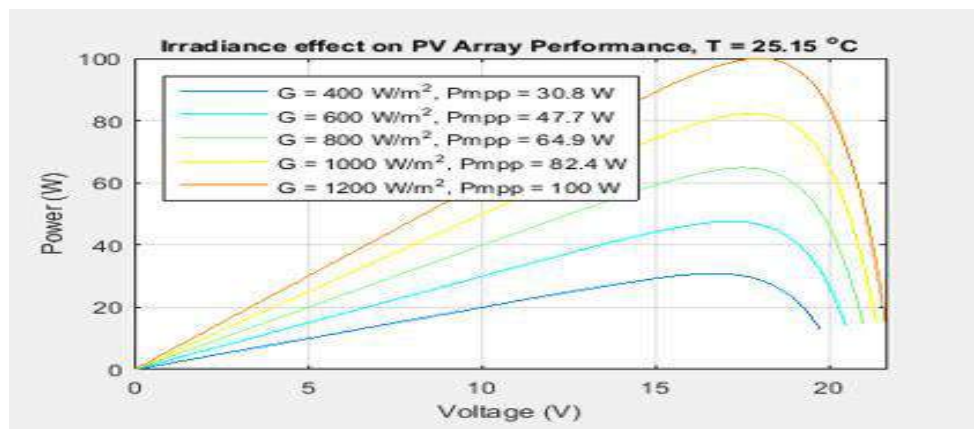

Fig. 3. 4: Deviation of MPP with IC under rapid solar irradiance changes.

MPPT USING FEED FORWARD NEURAL NETWORKS:

Feed Forward Neural Network (FFNN) is an artificial network that mimics the human biological neural networks behavior, widely used in modeling complex relationships between inputs and outputs in nonlinear systems. FFNN can be defined as parallel distributed information processing structure consisting of inputs, and at least one hidden layer and one output layer. These layers have processing elements called neurons interconnected together.

2. EXPERIMENTAL WORK

The Complete Control Strategy to connect the PV system with Grid.

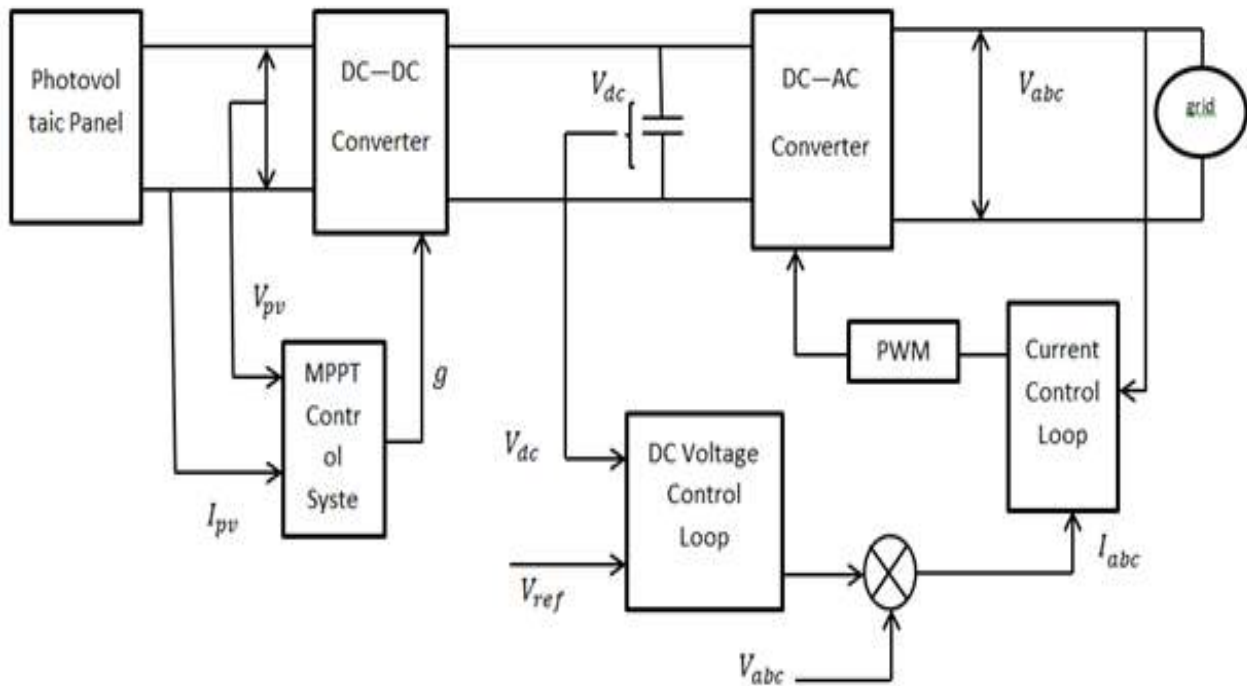

Fig.1.8 Control Strategy to connect the PV system with Grid

MPPT receive the PV voltage and current and generate a reference voltage and this reference voltage is coming from the MPPT. The output of the MPPT is fed to the PWM which gives the gate control signal to the DC_DC converter.

Another control topology is Inverter control which contains outer dc voltage control loop and inner current control loop. This control maintains the dc voltage constant and the dc power is converted to ac before transported to grid.

2.1 Modeling of 3-level bridge Inverter

In distribution power generation system three phase VSI are used to interfere between DC & AC system. For the control of active and reactive power along with constant DC link voltage different control technique are used to the three phase grid connected voltage source Inverter. Now a days power electronics converter are widely employed in all the application due to the switches non linearity occur in the system so the power stage must be line arised.

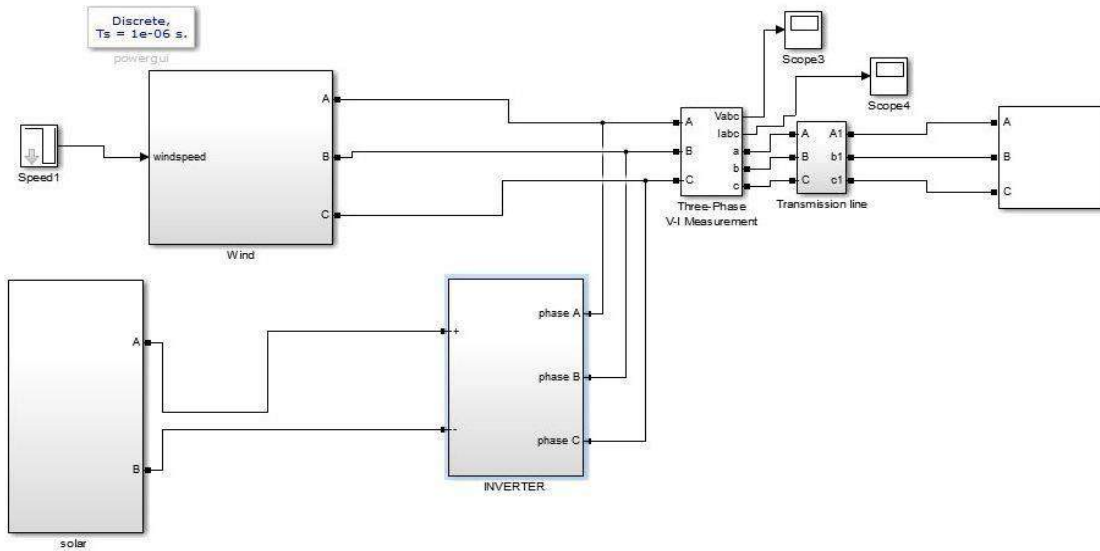

Fig 1.9 MODEL OF COMPLETE HYBRID SYSTEM CONNECTED TO GRID

3. Results and Discussion

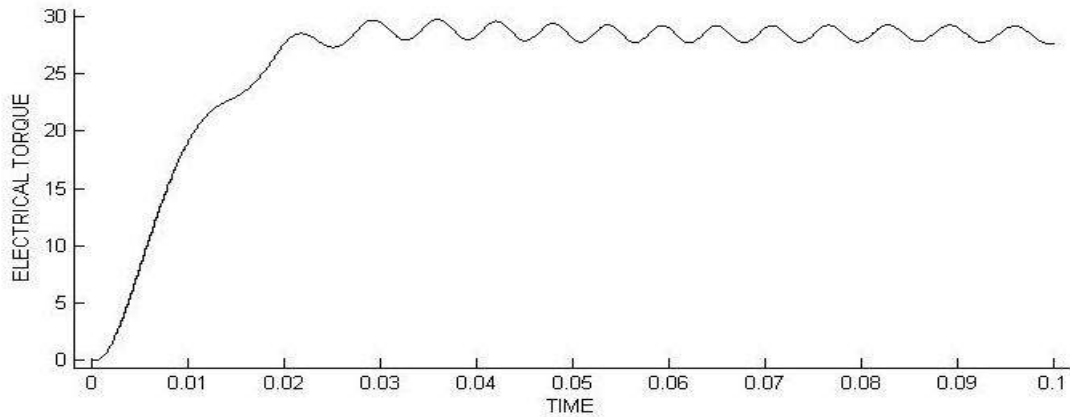

Fig 1.10 electrical torque developed by wind generator

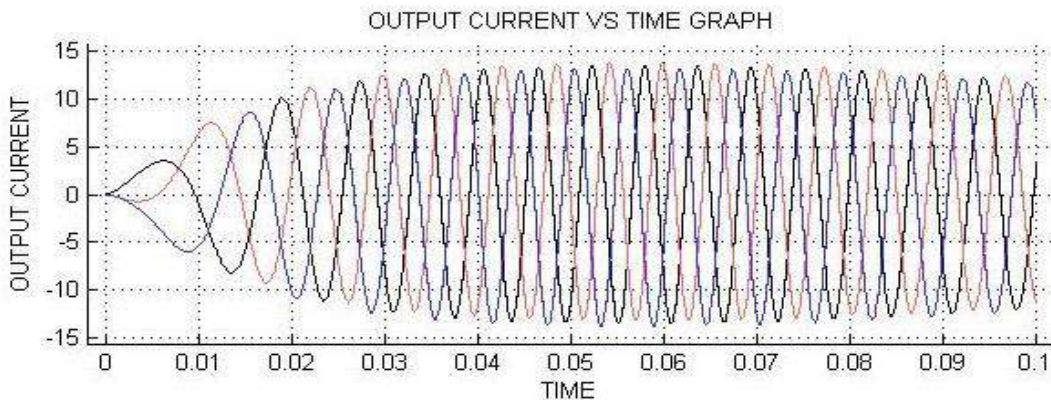

Fig 1.11 shows the variation of output voltage of the system

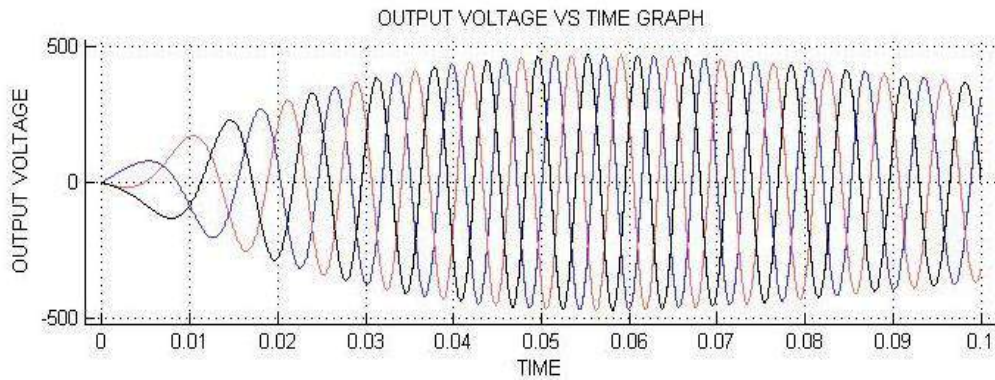

Fig 1.12 shows the variation of output current of the system

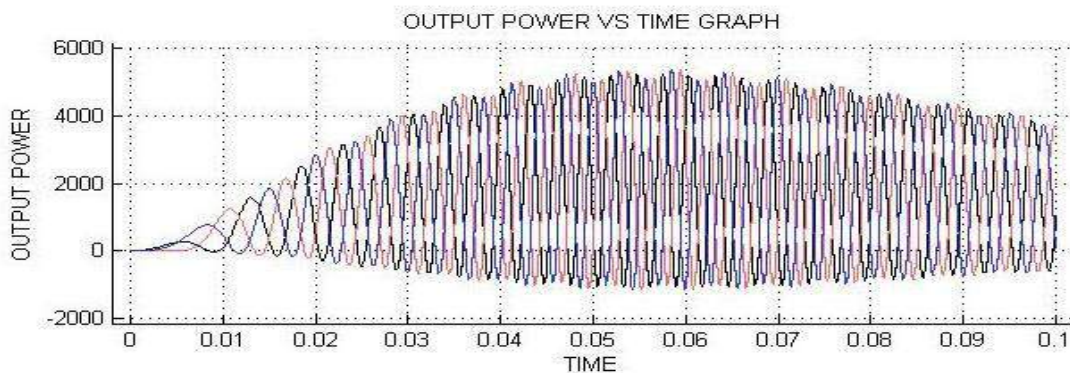

Fig 1.13 shows the output power generated by the system

A 60W PV module is modeled and simulated with varying irradiation and temperature. A boost converter is designed and simulated. To control the gate pulse of the high frequency switch of the boost converter MPPT algorithm are used.

The MPPT methods that is IncCond methods is used for maximum PowerPoint tracking. The Perturb and Observer algorithm is simple in operation and required less hardware as compared to Incremental Conductance Method but in this method the power loss is little more as compared to the Incremental Conductance Method due to the output of the PV array oscillate around the MPP. Similarly the Incremental Conductance Method has better control and smaller oscillation but the hardware requirement is more. The Incremental Conductance Method achieve its steady state value earlier than P&O method. There are many merits and demerits of the two method. Therefore all the features should be taken into account to choose a better control algorithm. In this project for comparing these two algorithms three series model and six parallel model is taken and simulated in Matlab/Simulink. From the simulation result it is observed that both the method give nearly same result. So the P&O method is chosen for the grid synchronization purpose because of its simplicity and easy implementation.

A dynamic model of wind turbine is model and simulated. PMSG is used in this paper as a wind generator due to its self excitation capabilities and requires less maintain. A 7.4kW out power is generated from the PMSG. A grid side VSI is used to synchronize the wind-PV hybrid system. The various waveform of this system were obtained by using the software Mat lab/Simulink. The simulation result showed excellent performance and the DC linked voltage is able to maintain at a constant level at 631.5 V from the wind – PV hybrid system with varying condition of wind and with different irradiation and temperature.

In future we can combine other hybrid system with this existing one like fuel cell or battery system can be added and by using matlab it can be analyzed.

References:

1. Seul Ki Kim, Eung Sang Kim, Jong Bo Ahn, "Modeling and control of a Grid connected Wind/PV Hybrid Generation System", 2005/2006 IEEE PES Transmission and Distribution Conference and Exhibition, 21-24 May 2006, pp. 1202-1207.
2. N. Pandiarajan, Ranganath Muthu, "Mathematical Modeling of Photovoltaic Module with Simulink", First International Conference on Electrical energy system (ICEES), 3-5 January 2011, pp. 258-263.
3. Munish Kumar, "Simulation and Analysis of Grid Connected Photovoltaic System with MPPT", 2012, IEEE 5th Power India Conference, 19-22 Dec. 2012, pp. 1-6.
4. Kun Ding, Xin Gao, Bian, "A MATLAB-Simulink-Based PV Module Model and its Application Under Conditions of Non uniform Irradiance", IEEE Transactions On Energy Conversion, Vol. 27, NO. 4, December 2012.
5. Ling Lu, Ping Liu, "Research and Simulation on Photovoltaic Power System Maximum Power Control" International conference on Electrical and control Engg (ICECE), 16-18 Sept. 2011, pp. 1394-1398.
6. Dezso Sera, Laszlo Mathe, Tamas Kerekes, "On the Perturb-and-Observe and Incremental Conductance MPPT Methods for PV Systems", July 2013 IEEE Journal of Photovoltaics, VOL. 3, no. 3, pp. 1070-1078.
7. Sibasish Panda, Anup Kumar Panda, "Fault Analysis on Grid Connected MPPT based Photovoltaic System", 2013 International journal of Current Engineering and Technology.
8. Natshes, E.M, "Modeling and Control for Smart Grid Integration of Solar/Wind Energy Conversion ssss System", Innovative smart Grid Technologies (ISGT Europe), 2011 2nd IEEE International Conference and Exhibition, 5-7 Dec. 2011, pp. 1-8.
9. D. Sera, R. Teodorescu, and P. Rodriguez, "PV panel model based on datasheet values", IEEE International Symposium on Industrial Electronics, ISIE, pp. 2392-2396, 2007.
10. J.G. Slootweg, H. Polinder, W.L. Kling "Representing Wind Turbine electrical generating system in fundamental frequency simulation", IEEE Trans. on energy conversion, Vol. 18, No. 4, December 2003, pp. 516-524
11. H. Polinder, F.F.A van der Pijl, G.J. de Vilder, P.J. Tavner, "Comparison of direct-drive and geared generator concept for wind turbine", IEEE Transactions on Energy Conversion, vol., 21, no. 3, pp. 725-733, Sept. 2006.
12. T. F. Chan, L. L. Lai, "permanent magnet machines for distributed generation: a review", Proc. 2007 IEEE power engineering annual meeting, pp. 1-6.
13. M. Fatu, L. Tutelea, I. Boldea, R. Teodorescu, "Novel motion sensorless control of stand alone permanent magnet synchronous generator (PMSG) : harmonics and negative sequence voltage compensation under nonlinear load", 2007 European conference on Power Electronic and Application, 2-5 Sept. 2007.
14. M. E. Haque, K. M. Muttaqi and M. Negnevitsky, "Control of a Stand alone variable speed wind turbine with a permanent magnet synchronous generator", Proceedings of IEEE power and energy society general meeting, pp. 20-24 July 2008.
15. M. E. Haque, M. Negnevitsky and K. M. Muttaqi, "A novel control strategy for a variable-speed wind turbine with a permanent magnet synchronous generator". IEEE Transactions on industry application, vol. 46, no. 1, pp. 331-339, Jan/Feb 2010.
16. N. Mohan, T. M. Undeland and W. P. Robbins, "Power Electronic: Converters, Application, and Design", Wiley, 2002.
17. W. D. Kellogg, M. H. Nehrir, G. Venkataramanan, and V. Gerez, "Generating Unit Sizing and Cost Analysis for Stand-alone Wind, Photovoltaic and Hybrid Wind/PV Systems", IEEE Trans. Energy Conversion, Vol. 13, No. 1, pp. 70-75, March 1998.
18. Fernando Valencaga, Pablo F. Puleston and Pedro E. Battaiotto, "Power Control of a Solar/Wind Generation System Without Wind Measurement: A Passivity/Sliding Mode Approach", IEEE Trans. Energy Conversion, Vol. 18, No. 4, pp. 501-507, December 2003.
19. Kurozumi, Kazuhiro et al, "Hybrid system composed of a wind power and a photovoltaic system at NTT Kume-jima radio relay station", INTELEC, International Telecommunications Energy Conference 1998, pp. 785-789.
20. Riad Chedid and Saifur Rahman, "Unit Sizing and Control of Hybrid Wind-Solar Power Systems", IEEE Trans. Energy Conversion, Vol. 12, No. 1, pp. 79-85, March 1997.
21. Francois Giraud and Ziyad M. Salameh, "Steady-State Performance of a Grid- Connected Rooftop Hybrid Wind-Photovoltaic Power System with Battery Storage", IEEE Trans. Energy Conversion, Vol. 16, No. 1, pp. 1-7, March 2001.
22. T. Esram, P.L. Chapman, "Comparison of Photovoltaic Array Maximum Power Point Tracking Techniques," IEEE Transactions on Energy Conversion, vol. 22, no. 2, pp. 439-449, June 2007
23. N. Femia, G. Petrone, G. Spagnuolo, M. Vitelli, "Optimizing sampling rate of P&O MPPT technique," in Proc. IEEE PESC, 2004, pp. 1945-1949.
24. Dr. Dharmendra Kumar Singh, Aman Upadhyay, Mr. Amit Agrawal, "Design and Simulation of Wind Energy Conversion System Synchronized with Electrical Grid Using DFIG" IJRITCC, Volume: 3 Issue: 7 ISSN: 2321-8169.
25. Dr. Dharmendra Kumar Singh, Aman Upadhyay, Mr. Amit Agrawal "Study Of Wind Energy Conversion System Connected To Grid Using Doubly Fed Induction Generator" IJRITCC | June 2015 Volume: 3 Issue: 6 ISSN: 2321-8169.