

## RFID based cashless system

<sup>1</sup>Ms. Manisha Gaikwad, <sup>2</sup>Ms. Komal kumari, <sup>3</sup>Mr. Pankaj Sawarkar, <sup>4</sup>Ms. Jyoti Rangari,  
<sup>5</sup>Ms. Pranali Faye, <sup>6</sup>Mr. Bharat Dhak

<sup>1-5</sup> UG Student, Priyadarshini J L College of Engineering, Nagpur, India.

<sup>6</sup> Asst. Professor, CSE Dept, Priyadarshini J L College of Engineering, Nagpur, India

<sup>1</sup>mannugaikwad15@gmail.com.

**Abstract:** RFID based cashless system aims at providing a comfort, tension free and easy way of travelling and also to reduce the man power. The challenges which are faced currently in the ticketing system mainly comprises of the formation of "Queues" for buying the tickets for local trains and also the change for money which we have paid is seem to be critical condition in railway ticketing system. This paper deals with the development and implementation of a system to buy the local train tickets which is simple and easy to use. Ticket can be bought with the help of a merchant card. The ticketing information of the user is stored in the database .A merchant card can scratch with the RFID system and RFID will match the card number with the stored information in database and proceed for buying the tickets. An OTP will generate on registered mobile number which then use for authentication. After authentication relevant customer can buy the tickets as per need, the total amount will be calculated and that much of amount will be deducted from the balance amount in the account as soon as the ticket will generate from the system.

**Key Words:** RFID, Sensor, Microcontroller, GPS, Merchant Card.

### 1. INTRODUCTION:

In this emerging world of computers, almost all-manual system has switched to automated and computerized system. Therefore, we are developing the software for "RFID Based cashless system" to model the present system and to remove the drawbacks of the present system. This project explores how computer technology can be used to solve the problem of user. This being a big step in terms of improvement in the railway system it is widely accepted across the country. Rather than designing manually, we have made use of computer. Use of computer has solved many problems, which are faced during manual calculation. Once data are fed, it can perform accurate functions. Therefore, to reduce the complexity and efficiency a versatile and an outsourcing railway reservation system has been developed. This project introduces railway reservation system. It explains how reservation is being done in Indian Railways. The ticketing information of the user is stored in the database. A merchant card can scratch with the RFID system and RFID will match the card number with the stored information in database and proceed for buying the tickets. An OTP will generate on registered mobile number which then use for authentication. After authentication relevant customer can buy the tickets as per need, the total amount will be calculated and that much of amount will be deducted from the balance amount in the account as soon as the ticket will generate from the system. RFID based ticketing system [1] aims at providing a comfort, tension free and easy way of travelling and also to reduce the man power. This paper deals with the development and implementation of a railway reservation by using merchant card. The ticketing information of the user is stored in the database. The software provides a comprehensive set of features to enhance the operational limits. Now one can easily plan the journey comfortably as the process is efficient and fast with being easy to access. The efficiency of the railway will increase result of computerization.

### 2. LITERATURE SURVEY:

The author **Prof. K. T. Patil, Dipti Mehendale, Vidya S., Aldar Leena Govilkar** describes in the "RFID Based Ticketing System For Local Trains.". The following components that would be included in this paper with their operations are as follows:

**Mobile Phone:** The first component will be a GPRS enabled mobile phone with an RFID chip attached to it. The mobile phone will be fed with an Android Application.

**RFID Reader:** The RFID Reader is the second component which is meant to be mounted on the wall of Railway Stations that would be accessible to the commuters.

**Server:** This is the most important component that is supposed to manage the entire system. The server will consist of the user database i.e. their unique ID's and a computer program coded in VB.NET. **RFID Tag:** The mobile user has an RFID tag attached to the rear panel of his mobile. One tag will be assigned to each passenger. This RFID tag has a unique ID, will be verified at server at station. The existing system is telling about the RFID tag would be on the rear panel of mobile phone which seems to be very less security to the RFID tag. Also it becomes inflexible to use it as to take the mobile phone in front of a RFID card reader and use for buying the tickets.

The author **T.Manikandan, G.Kalaiyarasi, K.Priyadharshini, R.Priyanga** describes of this "Conductor less Bus Ticketing System Using RFID and Accident Information through GPS and GSM" paper is to count the passenger using IR sensor and calculating the distance travelled by passenger automatically using motor and u-slot

sensor, and the corresponding amount is debited from RFID card. In addition to that, in proposal system the occurrence of accident information is automatically transmitted to the nearest hospital using GSM and GPS. In IR transmitter and receiver, IR transmitter is nothing but one type of LED, generally called IR transmitter. Initially IR transmitter and receiver are placed straight to each other, so the transmitted IR ray is received by IR receiver. But when passenger crosses the IR transmitter and receiver, the rays received will be interrupted. Here the micro controller used is Atmel 89C52, is flash type reprogrammable memory in which we have already programmed. So, signals received from SCU and increment the count value. Here RFID tag is rechargeable one, where as it can be recharged in bus depot or nearest retail shop. Micro controlled, keypad and LCD are provided in bus depot for recharging purpose by own.

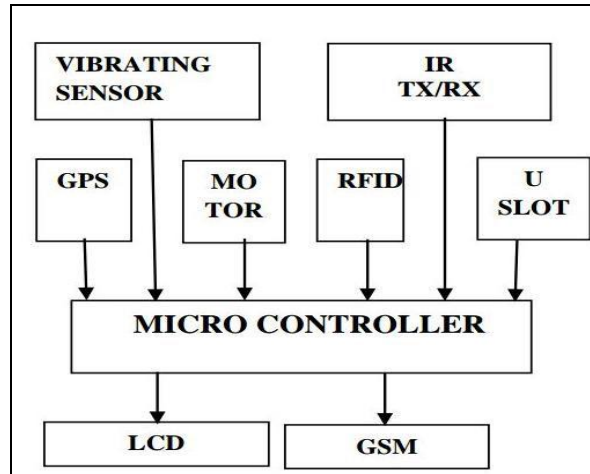

Figure 1. Microcontroller based System

The author **Piyush Chandra , Rakesh Kumar Keshri , Prakhar Soni** the paper “**RFID-based Ticketing for Public Transport System: Perspective Megacity**” based ticketing in public transport system, prevailing in the megacities introduces severe malfunction in the system, malicious argument among public, corruption and most of all traffic jams. This paper actually suggests a much more public friendly, automated system of ticketing as well as the credit transaction with the use of RFID based tickets. The total system mainly acts to bring out the consistency in the public transport system that will conclude in uniform access of passengers in daily rides through an automated server being updated every single time the passengers travel by carrying the RFID based tickets.

The author **Naga Lakshmi, Naga Raju** describes the paper “**IMPLEMENTATION OF FUTURISTIC E-TICKET BOOKING SYSTEM FOR PREARRANGED RAILWAY TRIP**”. Indian Railways has continuously endeavored to improve the ease and access of ticketing. The e-ticketing initiative of Indian Railways has been one of the most passenger-friendly initiative of Indian Railways. In order to further expand the reach of ticketing, the proposed system presents ticketing through mobile or GSM networks. The objective was to tap the potential of mobile or GSM network market in India and thereby facilitate the common man, by providing him any-where, any-time and hassle free booking option. This will enable people using non-internet based mobile phones and GSM systems to easily access Railway ticketing services through SMS. The system is user-friendly, secure and also eco-friendly, as no print out is required.

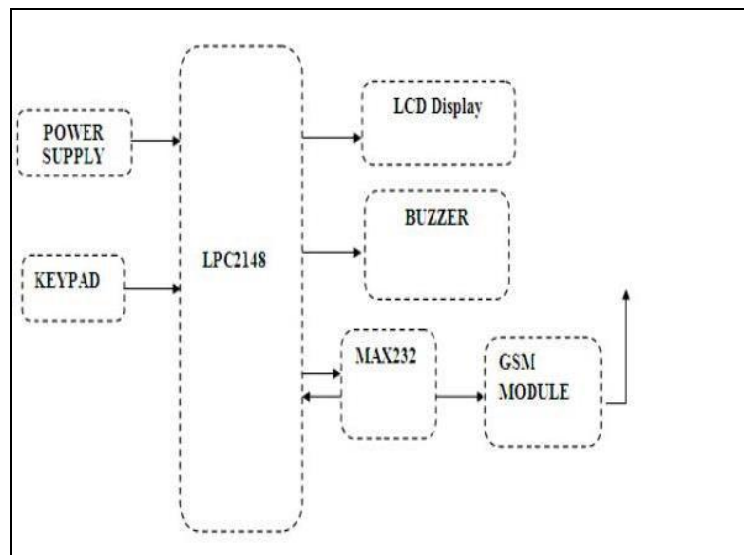

Figure 2 (a) Remote reservation section

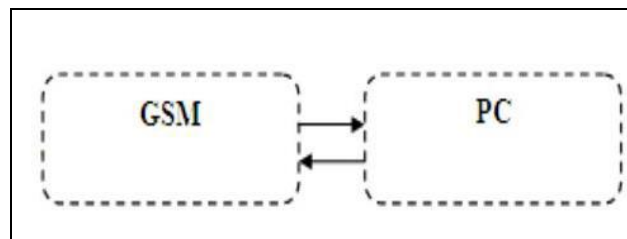

Figure 2 (b) Server Section

### 3. METHOD:

We are providing a RFID based cashless system software. This software is useful for those person which are interested in cashless system to book or reserve the railway ticket. In our proposed methodology we have provided various payment options as follows:

#### ONLINE PAYMENT OPTION:

- First phase is registration user can registered our self.
- After registration user can login in the software then getting a main menu and actual ticket booking process start.
- After compilation of ticket booking start Payment page.
- There are three option will present in this page.1. Debit card 2.credit card 3. Merchant card.

#### RAILWAY RESERVATION COUNTER:

This card is useful in railway reservation counter. User can scan card in rail counter because card is swap through the machine and user don't want to carry the coins and more cash.

Card will be available in railway counter and user want to register ourself with railway account.

#### MACHINE SYSTEM:

- Quos point
- Platform ticket
- Ticket booking

### 4. CONCLUSION AND FUTURE SCOPE:

By looking over to the present ticketing system in railway system ,it is very complicated with respect to time and money .Thus our project is completely ready to work for railways in ticket section to overcome all the complications regarding to money and time .We have successfully compile and test our project and it is ready to implement in a real time world.

This project can enhance in future as we can also make it available it with the mobile phone so that passengers can invoke their tickets hand to hand wherever and whenever necessary. And also it is very comfortable to survive with any modifications in future that can be extended.

### REFERENCES:

1. First International Workshop on Near Field Communication "NFC Ticketing: a Prototype and Usability test of an NFC-based Virtual Ticketing application", 2009.
2. Existing scenario of near field communication in transport sectorGautama, J. ; Kumar, Y. ; Gupta, A. Signal Processing and Integrated Networks (SPIN), International Conference on DOI: 10.1109/SPIN.2014.6776972Publication Year: 2014 , Page(s): 327 – 332, 2014.
3. A Distributed Integrated Fare Collection and AccountingSystem for Metropolitan Railway Transit Pint sangChang Ubiquitous Intelligence & Computing and 9th International Conference on Autonomic & Trusted Computing (UIC/ATC), 9th International Conference on DOI: 10.1109/UICATC.2012.147 Publication Year: 2012 , Page(s): 797 – 802, 2012.
4. Prof. K. T. Patil, Dipti Mehendale ,Vidya S., Aldar Leena Govilkar describes in the "RFID Based Ticketing System For Local Trains.
5. T.Manikandan, G.Kalaiyarasi , K.Priyadharshini , R.Priyanga describes of this "Conductor less Bus Ticketing System Using RFID and Accident Information through GPS and GSM.
6. Piyush Chandra , Rakesh Kumar Keshri , Prakhar Soni the paper "RFID-based Ticketing for Public Transport System: Perspective Megacity".
7. Naga Lakshmi, Naga Raju describes the paper "Implementation of Futuristic E-Ticket Booking System for Prarranged Railway Trip"